

ENGINEERED PRODUCTION EQUIPMENT, INC.

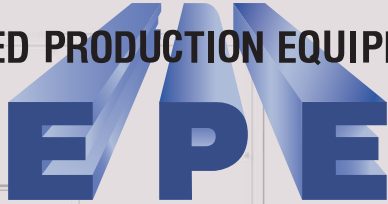

Designers and Builders of Custom Production Machinery

Model: RCP-650-7

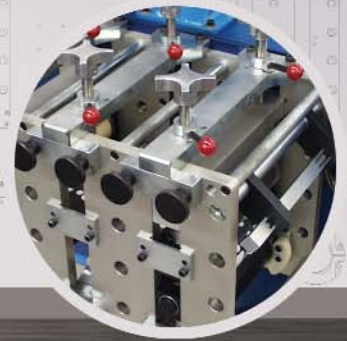
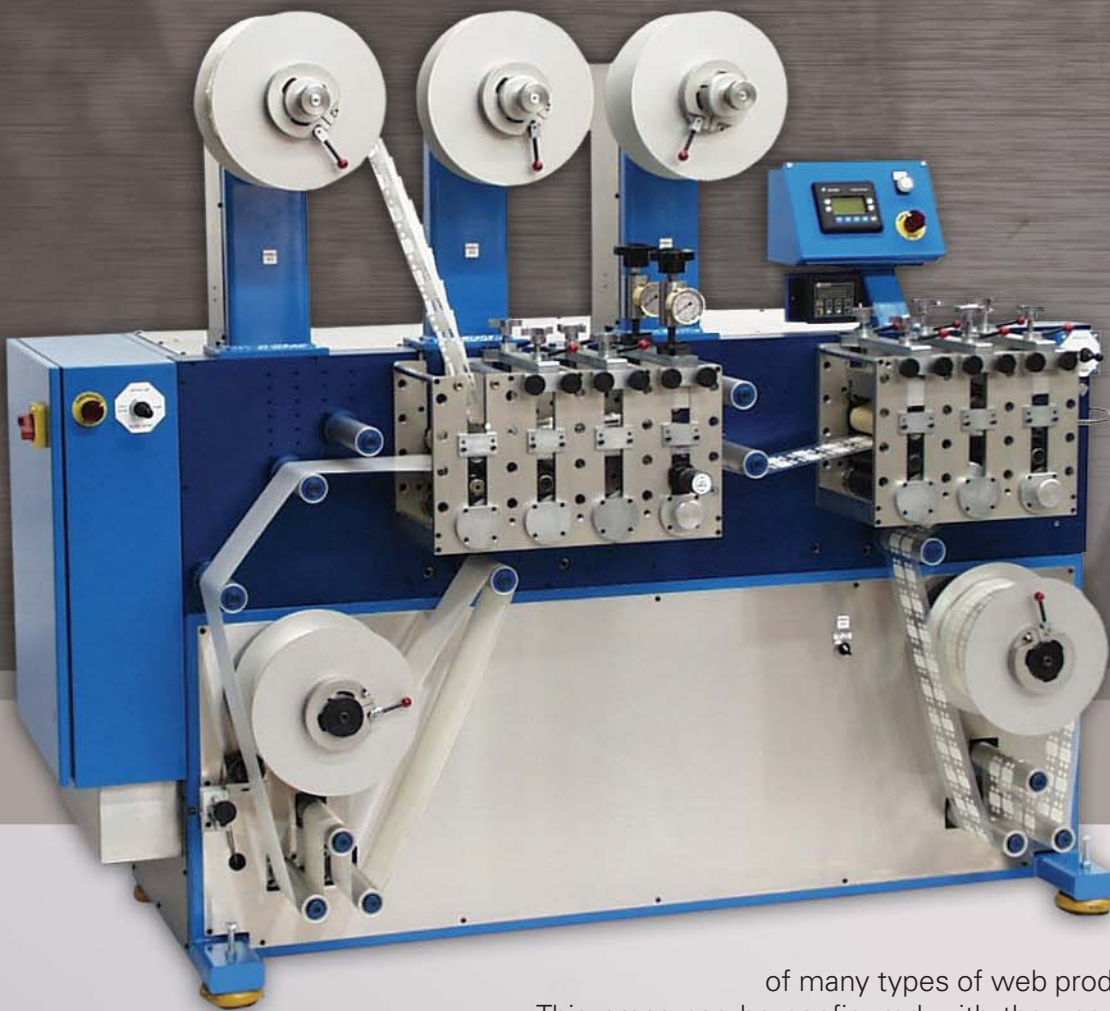

EPE's Rotary Converting Press has been designed to enable flexible production

of many types of web products in widths of up to 6-1/2".

This press can be configured with the use of seven drop-in diestations, which utilize industry standard rotary tooling, and with convertible upper payout and rewind spindles. The RCP-650-7 can efficiently accommodate your rotary converting needs. This press may be set up for converting operations such as laminating, delaminating, diecutting, kiss-cutting with waste removal, and other custom processes specific to your product requirements. EPE can customize your RCP-650-7 with specialized options and upgrades such as closed-loop tension control, web guiding, additional payouts and rewinds, servo-registered diestations, and printing/coding equipment.

*Some photos may show the machine with optional equipment installed.

Model: RCP-650-7

Dimensions are in inches.

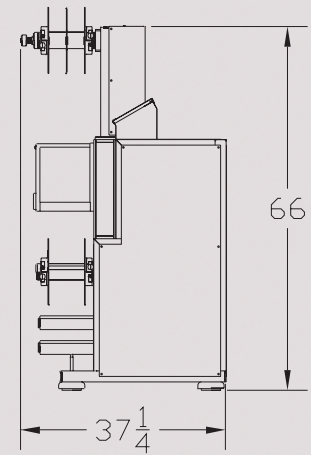
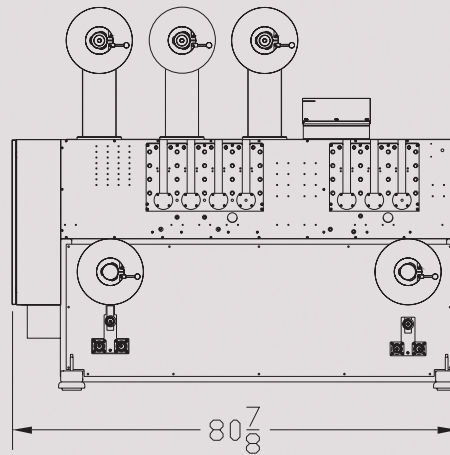
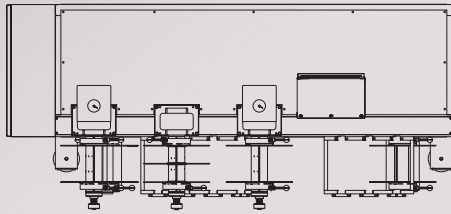

FEATURES

Web Payout Spindle: Used to unwind the base web material. A splice plate is provided to facilitate web splicing.

Web Rewind Spindle: Finished product web or product scrap from a blanking process can be wound up on this spindle.

Convertible Upper Payout/Rewind Spindles: The three upper spindles can be easily switched between payout or rewind functions by the operator.

Web Tension: Manually adjusted pneumatic brakes and clutches allow the operator to adjust the web tension generated by the spindles.

Diestations: Cantilever-mounted diestations with removable drive rolls accept industry-standard tooling in seven T-slot style tool stations. These tool slots may be filled with various tooling combinations as is necessary for your converting process. The tool slots are each topped by a quick-attach pressure bridge, equipped with two die pressure screws to create the tooling force. The diestations are also equipped with multiple idler roller mounting locations to enable optimization of the web paths in and out of the diestations.

Nip Drive Station: One of the seven tooling slots, usually station six, will be utilized for the main web drive. A drop-in, traction-coated anvil roller and a rubber coated nip roller will serve to pull the web through the press.

Adjustable Registration Toolstations: The fourth and seventh tooling slots are equipped with manually-operated registration adjustment knobs that allow the operator to fine-adjust the registration of the tooling in that slot.

Operator Panel: Provides the operator interface to the machine.

OPTIONS

Automatic Tension Control: Tension feedback rollers and upgraded controls allow closed-loop tension control, ensuring consistent and repeatable web tension throughout the production run. May also be upgraded to magnetic particle clutches and brakes for all-electronic tension control and cleanroom compatibility.

Web Steering/Guiding: This equipment allows more consistent cross-web positioning of the web, correcting for poorly wound or 'telescoped' input rolls.

Additional Adjustable Registration Toolstations: Manual registration equipment may be added to other toolstations.

Multi-Roll Spindle: Multiple rolls of material may be unwound or rewound onto a single specialized spindle. Used when laminating multiple narrow webs or slitting one web into many.

Electronic Toolstation Registration: Automatic electronic tooling registration, to the base web features, can be achieved by driving an individual toolstation with a servomotor that utilizes a sensor to detect the features in the base web.

Tool Stack Pressure Monitor: The tool stack pressures may be monitored via hydraulic pressure gauges or electronic load cells and displays.

Adjustable Kiss-Cut System: Provides the means to adjust 'depth of cut' in very small increments in order to precisely control die penetration on sensitive diecutting applications.

Web Printing/Coding Systems: Various web printing and product coding systems may be incorporated into the press.

SPECIFICATIONS

Pouch Material Web Width: 6.5" maximum

Payout/Rewind Spindles: 12" diameter with 3" air expanding cores

Maximum Tooling Repeat: 15"

Machine Speed: Adjustable up to 100 feet / minute

Power Requirements: 220 VAC, 1-Phase, 60 Hz, 15 Amps

Physical Specifications:

Length: 80-7/8" Depth: 37-1/4" Height: 66"

EPE is a custom equipment manufacturer with years of experience building custom web handling and packaging equipment. Contact us with your special requirements.

ENGINEERED PRODUCTION EQUIPMENT, INC.



Designers and Builders of Custom Production Machinery